

Preliminary design of a coffee harvester

Projeto preliminar de uma derriçadora de café

Raphael Magalhães Gomes Moreira^{1*}; Mauri Martins Teixeira²;
Fábio Lúcio Santos³; Haroldo Carlos Fernandes²; Paulo Roberto Cecon²

Abstract

Design of an agricultural machine is a highly complex process due to interactions between the operator, machine, and environment. Mountain coffee plantations constitute an economic sector that requires huge investments for the development of agricultural machinery to improve the harvesting and post-harvesting processes and to overcome the scarcity of work forces in the fields. The aim of this study was to develop a preliminary design for a virtual prototype of a coffee fruit harvester. In this study, a project methodology was applied and adapted for the development of the following steps: project planning, informational design, conceptual design, and preliminary design. The construction of a morphological matrix made it possible to obtain a list of different mechanisms with specific functions. The union between these mechanisms resulted in variants, which were weighed to attribute scores for each selected criterion. From each designated proposal, two variants with the best scores were selected and this permitted the preparation of the preliminary design of both variants. The archetype was divided in two parts, namely the hydraulically articulated arms and the harvesting system that consisted of the vibration mechanism and the detachment mechanism. The proposed innovation involves the use of parallel rods, which were fixed in a plane and rectangular metal sheet. In this step, dimensions including a maximum length of 4.7 m, a minimum length of 3.3 m, and a total height of 2.15 m were identified based on the functioning of the harvester in relation to the coupling point of the tractor.

Key words: Project methodology. Mountain coffee production. Machine design.

Resumo

Projetar uma máquina agrícola é altamente complexo devido às interações entre o operador, a máquina e o meio ambiente. A cafeicultura de montanha é um setor que requer investimentos para o desenvolvimento de máquinas agrícolas, a fim de melhorar os processos de colheita e pós-colheita e suprir a escassez de trabalhadores no campo. O objetivo deste estudo foi desenvolver um projeto preliminar para o protótipo virtual de uma colhedora de frutos de café. Para isso foi aplicado e adaptada uma metodologia de projeto, para o desenvolvimento das etapas de: Planejamento do Projeto, Projeto Informacional, Projeto Conceitual e Projeto Preliminar. A construção de uma matriz de morfológica possibilitou listar diferentes mecanismos com funções específicas. A união entre os mecanismos resultou em variantes que foram julgadas para atribuir pontuações para cada um dos critérios selecionados. Entre todas as variantes propostas, duas foram selecionadas, pois atingiram pontuações mais elevadas, permitindo a preparação do projeto preliminar de ambas as variantes. O arquétipo foi dividido em chassi, tendo seus braços articulados hidráulicamente e o sistema de derriça, composto pelos mecanismos de vibração e o mecanismo de derriça com a inovação que foi proposta com hastes paralelas entre si fixadas em uma chapa plana e retangular. Na etapa foi identificada comprimento máximo de 4,7 m (mínimo 3,3 m) e uma altura total de 2,15 m no funcionamento da derriçadora em relação ao ponto de acoplamento do trator.

Palavras-chave: Metodologia de projeto. Cafeicultura de montanha. Projeto de máquinas.

¹ Prof., Instituto Federal do Espírito Santo, Ifes, campus Itapina, Colatina, ES, Brasil. E-mail: raphael.eaa.ufv@gmail.com

² Profs., Universidade Federal de Viçosa, UFV, Viçosa, MG, Brasil. E-mail: mauri@ufv.br; haroldo@ufv.br; cecon@ufv.br

³ Prof., Universidade Federal de Lavras, UFLA, Lavras, MG, Brasil. E-mail: fabio.santos@deg.ufla.br

* Author for correspondence

Introduction

Creative capacity is associated with one or more methodologies for the development of a design. The aim of creative capacity includes attending in a highly efficient manner to the needs of both the user as well as the designer, thereby decreasing risks in a relevant way (PADILHA et al., 2010). The main goal in developing an innovation lies in the maximum feedback that the innovation could provide for users. An innovation achieves success with the support of proposed guidelines and different methodologies (GRZEBIELUCKAS et al., 2011). The acknowledgment of an innovative product may be the result of an information exchange between designers and agriculturists, since the demands arise from a specific need in the management of operations in the coffee fields (AHRENS et al., 2007; ALBIERO et al., 2011).

Project methodology for the development of agricultural machinery contains sequences that could be separated in the stages of project planning, informational design, conceptual design, preliminary design, and detailed design. These sequences, when accomplished by the construction of flowcharts, allow the innovative achievement of production, preparation, and product launch (ALBIERO et al., 2007; ROMANO, 2013; SEVERO et al., 2014). Conversely, Almeida et al. (2012) verified that the major flexibility of design management resulted in better conditions for the accomplishment of a highly innovative product.

Product development could follow systematic design methodologies. The model of steps is an example of a design methodology. The model in this study employs client identification and the need of the client in a similar way (PAHL et al., 2005; STEFANELLO et al., 2014). In accord with Albiero et al. (2011, 2012), by observing the ambient of work and following the steps presented by Albiero et al. (2007), it was possible to develop innovative concepts during the construction of numerous prototypes. These prototypes could result in the optimization of harvesting operations and improvements in the operational capacity, incomes,

and work conditions, which in turn is related to the reduction of negative impact on the previously implemented crops.

Methodology proposed by Pahl et al. (2005) applied methods ranging from a qualitative analysis to a quantitative analysis to the project steps in a most appropriate manner. It is necessary to possess and apply knowledge on both engineering as well as on project methodology to avoid mistakes in the conception, decision-making, and failures during the operation of prototypes (ROMANO, 2003; MOREIRA et al., 2013).

As per the Coffee Statistic Bulletin (MAPA, 2014), Brazil's share of the global production of coffee in 2014 was equivalent to 32.16%. Additionally, Brazil occupied the first position in global coffee export, which was 32.2%. The export of Brazilian coffee represents US\$ 6,661,875.00 in monetary value, and it constitutes 6.9% of all the agricultural products.

Given the total coffee production (Arabica and Robusta coffee beans) from the 2014 Brazilian crops, the number of processed coffee bags (more than 45.3 million), the geographic heterogeneity of coffee production, and the use of technologies, mechanization in coffee agriculture is an extremely important process (MAPA, 2014). In 2014, the State of Minas Gerais contributed to 50% of national production despite a decrease in the harvesting work force. According to a survey conducted by the Brazilian Coffee Institute (IANES, 2010), 38% and 58% of Forest Zone and the South Region, respectively of the State of Minas Gerais considered the work force as insufficient.

The growing importance of harvesting mechanization is necessitated by the decrease in the coffee agriculture work force. The challenges faced by the machine designers include the irregular form of the fruits (MAGALHÃES et al., 2000), different plant architectures, and heterogeneous topographic and farming configurations. Nevertheless, machine designers target the development of efficient and better-adapted machines by using project methodologies (RUGANI; SILVEIRA, 2006).

Coffee production consists of six steps: coffee tree canopy cleaning, harvesting, sweeping, gathering, fanning, and transportation. In this productive process, harvesting is considered as the most expensive step, given the huge demand on time and the low operational capacity, especially when it is manually executed (SILVA; REIS, 2001; CARVALHO JÚNIOR et al., 2003). Approximately 40% of the temporary workers in the coffee fields are required in the harvesting step. This elevated demand on the work force results in higher costs, which could exceed 30% to 35% of the global production cost (CIRILLO JÚNIOR, 2007). Hence, this study considers this reality and presents an elaborate virtual design of a harvester machine for the coffee fruit plantations in mountainous regions where the coffee producers have implemented the terracing technique. The design incorporates a project methodology initially proposed by Pahl et al. (2005) in order to allow for a realistic design.

Methodology

The Agricultural Mechanization Lab (LMA) team at the Department of Agricultural Engineering in the University of Viçosa (DEA-UFV/ Minas Gerais, Brazil) idealized the prototype of a coffee harvester for mountain regions. Hence, the design development in this study was based on the methodology proposed by Pahl et al. (2005). The methodology consists of a general process involving simple solutions that contemplate confronting of tasks with respect to their results. At the end of each step, there is a gain in information, which is fed into the next step. The steps include project planning, informational design, conceptual design, preliminary design or pre-design, and detailed design.

Project planning

Initially, the project planning was developed in a simple way given that it is considered by extant researches to be an extremely subjective and creative step. The planning consisted of defining a design team composed of a titular professor

and coffee producer, a professor with a Ph.D. in the area of mechanization, a doctoral candidate, a master's degree candidate, a technician from the mechanization sector, an undergraduate student, and also a coffee producer. The design team was able to judge and choose a problem related to certain steps of the coffee harvesting process. The lack of work force and the low operational capacity of coffee fruits harvesting acted as the motivators in choosing the problem, given that the entire process was manual. The fields of observation included symposiums and meetings on coffee agriculture and testimonies of the coffee producers in the regions of Viçosa, Teixeiras, Canaã, and Araponga, as well as from the cities of Minas Gerais' Forest Zone.

Informational design

Based on selected information from the project planning, in which the needs and requirements were verified, the informational design step that involved the search for operation principles was initiated. These principles included searches on the state of technology in expositions, bulletins, catalogs, patents, evaluation, and criticism of the interrelation between existent solutions, operational principles, and the problem in question. Given its considerable importance, a detailing of the state of art presented by Moreira (2015) was considered next in the conceptual design step.

Conceptual design

After collecting the information from the previous steps, the conceptual design step, which constitutes the most important step (ROMANO, 2003) was developed and realized by the construction of a requirement list. This list was elaborated based on steps involving information, definition, creation, evaluation, and decision in order to potentially answer certain questions related to the finality, and to ensure that the solution satisfies the problem and the characteristics presented by the solution (PAHL et al., 2005; ALBIERO, 2012).

The above-mentioned list establishing the requirements that the archetype of the harvester design may present in its conclusion was formulated by disregarding criticisms on the technical or economic viability of the harvester archetype. This list could be modified at any point during the design development, but it was necessary to show the modifications in accordance with the day and the time of their realization. At the conclusion of the design development, the evaluation with respect to the adequacy or inadequacy of the archetype with respect to the proposed requirements was considered. The case of the inadequacy of the archetype, indicated the occurrence of a mistake in the planning step or in the list of requirements.

Following certain procedures from the methodology proposed by Pahl et al. (2005), the construction of a sub-functions matrix was developed. In this, specific functions that the archetype may realize during its functioning were developed with the purpose of achieving the goal proposed by the design team. These functions were defined with respect to mechanisms involving controlling, pulling, structuring, gyrating, sustaining, and harvesting. After generating these sub-functions and listing their respective solving mechanisms, a solution or mechanism for each sub-function was chosen, and this resulted in a grouping termed as the solution variant. An increase in the number of proposed variants resulted in an increase in the possibility of creating design solutions that supplied the totality of tasks for each task idealized in the archetype. However, it was important to connect the complexity of this work directly to the quantity of the proposed variants (PAHL et al., 2005; ALBIERO, 2012).

The variants selected by the design team were evaluated for details of positive and negative points of the proposed solutions by considering criteria including low construction cost, low operation cost, harvester efficiency, ease of operation of the harvester, applied technology, ease of operation of the harvester inside the coffee fields, ease of

maintenance, higher reliability, and the ease of fabrication and repositioning of the components. Members of the design team evaluated these variants by weighing and attributing a score on a scale for each mechanism used in each one of the sub-functions. Hence, it was possible to define the design properties of the harvester. With respect to the definition of the best variant, the method used involved a score for each mechanism from each sub-function of the harvester. The rating system ranged from the highest value (5), which indicated that the harvester had accomplished its sub-function expectations, to the lowest grade (0), which indicates that the harvester was unable to accomplish the required tasks. The ratings given by each team member were collected and combined resulting in a unique average value. Each grade represented the analysis of a logical factor, and it could not be compared with grades for other mechanisms previously used in the same sub-function of another variant.

Preliminary design

In the preliminary design, the archetype architecture corresponding to the variant that obtained the highest score was defined and generated in conjunction with the information from the previous steps. The harvester definition served for the comprehension of all the structural parts. The creation step in the CAD platform served for the understanding of existent interactions between the constituent parts and for a better construction of the mechanisms. In this step, the design was realized in accordance with technical and economic criteria. From this point to the next steps, the archetypical model evolved from a definitive drawing of the product, thereby highlighting the fact that the team could proceed with certain justified alterations in the design at any point of time.

This step was intimately connected to its antecedent because the parts generated with its dimensions, tolerances, and joints or articulations

achieved the archetype development, wherein the materials could be characterized, all the mechanisms could be fixed, and the scale of the harvester could be potentially verified.

Results and Discussion

Project planning

In the project planning, the methodology described by Pahl et al. (2005) was utilized with certain adjustments to totally or partially resolve the lack of work force problem, and it was identified with respect to the harvesting and detachment steps. In this step, detachment was defined as the rupture of the coffee fruits peduncle in one of its extremities or the total disruption that resulted in the detachment of coffee fruits from its branches.

Informational design

Moreira (2015) detailed the informational design and referred to it as the state-of-art. Moreira's study presented some results based on searches in which the design team had judged pertinent information, and extracted information from patents, extension bulletins, search engines, company websites, and area journals and magazines. The findings of this study resulted in the selection of devices (Reselca and Alfa) for manual harvesting, as well as the choice of portable harvesters (Descafé, Coffea shaker and the vibratory little hands from different companies). In patents related to the coffee fruit crop and harvesting devices, the beater cylinder, the vibration mechanism, the track harvester, and fish-spine devices are of importance (Moreira, 2015).

The archetypes in patent form mention the lateral harvester attached to the tractor chassis, the citrus harvester attached to the tractor traction system, and the pneumatic harvester and the oblique automotive harvester involving the movement of detachment cylinders. The Dragão Versati, Kokinha, KTR, Korvan, K3500, and Braud 9090 x are important examples of self-propelled and conjugated

harvesters. When the informational design step is completed, the collected information served as a guideline to construct the conceptual design of a coffee fruits harvester for mountainous regions.

Conceptual design

In the conceptual design, a requirements list (Table 1) was formulated by establishing steps including information, definition, creation, evaluation and decision as a basis. The requirements list must answer questions related to the purposes that the solution could satisfy and the characteristics that it could present (PAHL et al., 2005).

Table 1. Requirements List.

Requirements List – 6/11/2012 12pm
Replacement work force
Harvesting of coffee fruits
Movement in inclined grounds
Robustness
Ease of construction
Durability
Move appropriately
Attachability
Safety
Economic viability
Appropriate execution of tasks
Operational capability

The selected requirement must allow for the following: a partial substitution of the work force engaged in the coffee fruit harvesting operations; a possibility of the archetype to attend to other tasks such as pruning, pulverization and fertilizing, which in turn may have an impact on the distribution of acquisition costs and the maintenance of the archetype; a lower cost of the machinery by taking depreciation and investments into consideration and presenting the values closest to the work force costs.

After the creation of the pre-requirement list, the morphological matrix mentioned by Pahl et al. (2005) was constructed. This matrix (Figure 1)

allowed the union of sub-functions, combined in different ways to obtain a higher number of solutions with variability. Specific solutions could satisfy the proposed functions that the coffee fruits harvester archetype may accomplish during its functioning, to achieve the goals proposed by the designers. These solutions were planned by the use of drawings, with the purpose of promoting an evaluation of the combinations. Given the combinations in conjunction with the sub-function solutions, a list of variants was created with the global quantity of 32 possible solution variants. From this list, five variants were selected (Table 2) to evaluate and detail positive and negative aspects of the proposed solutions.

After the evaluation, the design team excluded the sustenance function because of the non-pertinence of this function in the design. Additionally, the attribution of scores to the variants as presented in Table 2 was initiated. In order to create Table 3, the variants that achieved scores higher than 4.0 points were selected. In this table, it was possible to verify

the score assigned to each evaluation criteria and to multiply this value with the weight/importance (V. weight).

In Table 3, it was also possible to observe that variants 19 and 20 presented identical and the highest scores (4.78) among the judged variants. Hence, both variants were selected for the preliminary and detailed design steps. Variants 19 and 20 presented a harvester controlled by remote control handles in the tractor hydraulic system. These handles possessed articulated arms and it was assembled in three points on the tractor. Hydraulic cylinders were responsible for the arms movements, and rubber tires with traction grabbers were responsible for the gyre. Variants 19 and 20 differed with respect to the detachment mechanism, as the detachment mechanism in the variant 19 was composed of sticks radially disposed around an (commercial) axis. In contrast, the detachment mechanism in variant 20 was composed of parallel rods fixed in a rectangular plaque, and the design team considered this as an innovative technique.

Figure 1. Matrix of sub-functions and solutions for the functions.





























		Solução						
		1	2	3	4	5	6	7
Movimentação da derrçadora na lavoura de café	Operação da derrçadora	(Manual) Alavancas do Controle Remoto 	(Manual) Joystick 	(Automatizado) Scanner 	(Automatizado) Sensores 			
	Tracionar	Animal 	Automotriz 	Tratorizada Montada (3 pontos) 	Tratorizada Arrastada (Barra de Tração) 			
	Estruturar	Chassi fixo 	Chassi articulado 	Braços articulados 				
	Girar a máquina	Cilindros Hidráulicos 	Pinhão e Cremalheira 	Pinhão e coroa 	Engrenagens cilíndricas 	Engrenagem com parafuso sem fim 	Correntes 	Polias 
	Sustentar	Pneu de Borracha de 	Pneu de Borracha 	Pneu Metálico 	Patim 	Esteira metálica 	Esteira de Borracha 	
	Derriçar	Pneumático (positivo) 	Pneumático (negativo) 	Vibração de Varetas radiais 	Vibração de Varetas Paralelas 			

Table 2. Results with some variants.

Group of solution variants	Function					
	Control	Tracing	Structure	Movement	Sustainability	Harvesting
Var.18	Remote control handles	Settled	Articulated arms	Hydraulic Cylinders	Rubber tire	Pneumatic (pressure -)*
Var.19	Remote control handles	Settled	Articulated arms	Hydraulic Cylinders	Rubber tire	Radial Sticks
Var.20	Remote control handles	Settled	Articulated arms	Hydraulic Cylinders	Rubber tire	Radial Sticks
Var.21	Remote control handles	Settled	Articulated arms	Gear with worm	Rubber tire	Pneumatic (pressure +)**
Var.22	Remote control handles	Settled	Articulated arms	Gear with worm	Rubber tire	Pneumatic (pressure -)*

Table 3. Variants that obtained an additional value to the scores, with ratings exceeding 4.0 points

Evaluation criteria	Weight	Solution variants									
		18		19		21		22		20	
		Score	V. Weight	Score	V. Weight	Score	V. Weight	Score	V. Weight	Score	V. Weight
Low construction cost	0.06	3	0.18	5	0.3	5	0.3	5	0.3	5	0.3
Low operation and maintenance cost	0.06	3	0.18	4	0.24	5	0.3	4	0.24	4	0.24
Efficient detachment	0.20	4	0.8	5	1	2	0.4	4	0.8	5	1
Ease of operation of the harvester	0.16	5	0.8	5	0.8	5	0.8	5	0.8	5	0.8
Applied technology	0.08	4	0.32	4	0.32	4	0.32	4	0.32	4	0.32
Ease of operation of the harvester inside the coffee fields	0.20	5	1	5	1	5	1	5	1	5	1
Ease of maintenance	0.16	4	0.64	5	0.8	4	0.64	3	0.48	5	0.8
Higher reliability and easy fabrication or repositioning of components	0.08	4	0.32	4	0.32	4	0.32	4	0.32	4	0.32
Total with weight	1	4.24		4.78		4.08		4.26		4.78	

Preliminary design

In the design draft step, a composition of the harvester archetype was defined and divided in two basic parts, namely the chassis and the detachment system. A hydraulic fluid reservoir, a hydraulic control system and articulated arms integrated the

chassis. The reservoir (Figure 2a) had the function of storing the hydraulic fluid, serving as an attachment at three tractor points, and also acting as a support for the entire hydraulic system command. Articulated arms called gyre arms (Figure 2b), uprising arms (Figure 2c), and extensor arms (Figure 2d), together with hydraulic cylinders functioned to promote

sustenance and movement in the vibration and detachment systems. These articulated arms also permitted the movement of the detachment system,

which was necessary to handle the movement through a planting line area, or to act on situations involving retraction of the vibration and detachment mechanisms to the side of the tractor.

Figure 2. (a) Articulated arms reservoir. Articulated arms (b) of the gyre, (c) uprising, and (d) extension.

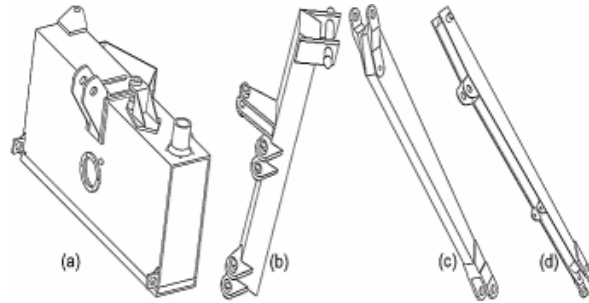

The vibration mechanism and the detachment mechanism were two essential constitutive parts of the harvester system. The constitution of the vibration mechanism involved an articulated support, a hydraulic motor, and an eccentric rotating mass. The support was virtually constructed by using sheet metal steel 1020, with a thickness of 0.01 m and a weight of 43 kg (Figure 3). Its function involved sustaining the hydraulic motor, interconnecting the articulated extensor arm to the eccentric rotating mass with pedestal bearings, and allowing at least two degrees of operational freedom to the detachment system. With respect to the

eccentric masses composition, a maximum of four cropped metal sheets were set in a semicircle with a diameter of 0.24 m and a thickness of 0.016 m by using steel 1020, drawing axes of 0.25 m diameter in steel 1020, bearings, and ball bearings (Figure 3). The functional principle of the vibration mechanism was based on the moment generated by the rotation of the eccentric masses vibration mechanism axis, in the same direction, and in a binary way in relation to the central axis of the detachment mechanism. The activation of the vibration mechanism axis was responsible for its rotation, and a hydraulic motor operates it with pulleys, sprockets, belts and chains providing the movement transference.

Figure 3. Support scheme with the vibration mechanism.

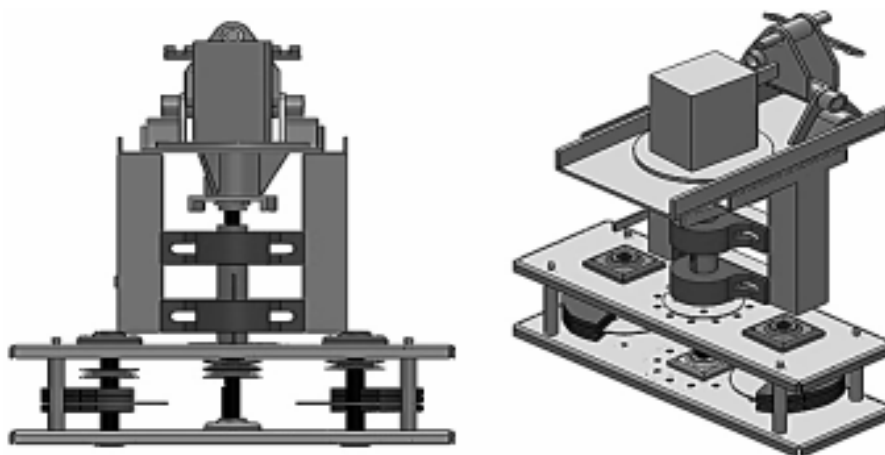

Eccentric masses have flexibility in terms of the number of sheet metal steel 1020 used in its composition, the factors influencing the eccentricity, the factors that may be responsible for increasing the vibration amplitude on the detachment mechanism, and the global weight of the conjunct that determines the impact force of the rods.

By analyzing the results presented in Table 2, an initial draft with two variants that obtained

the highest scores was designed. Variant 19 had a detachment mechanism composed of a detacher cylinder and of radial sticks circulated by a cylindrical axis (Figure 4a) attached with steel flanges. This structure was widely used in several crop and harvesting machines with the focus on coffee fruits and congeners. Variant 20 consisted of a detachment mechanism with sticks perpendicularly disposed on a rectangular plaque with lateral and posterior reinforcements (Figure 4b).

Figure 4. Radially disposed sticks and harvester cylinder axis. The sticks were perpendicularly disposed on the rectangular plaque.

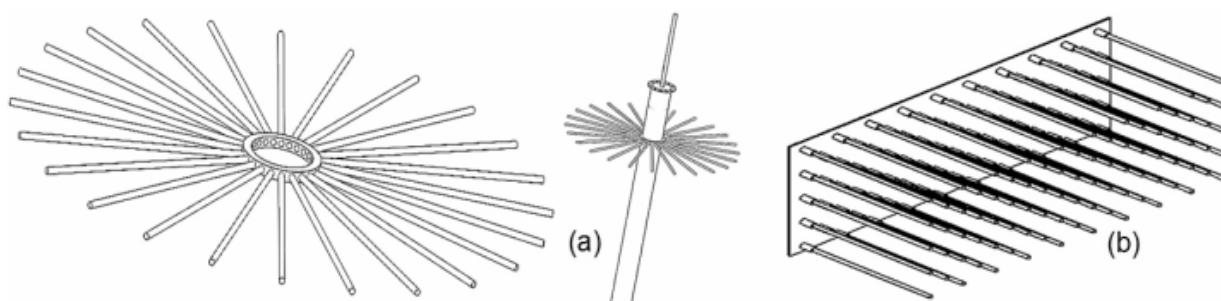

The final step was intimately connected to the previous step, since the pieces generated with its dimensions, tolerances, and joints or articulations achieved the development of the virtual archetype, wherein the materials were finally characterized and all the components were fixed. With the purpose of optimizing the detailed project, a search was conducted that involved companies, which include articulated arm systems already consolidated in the market in their portfolios. This search resulted in the selection of the application of Hydraulic Articulated Harvester Lavrale® commercial chassis, serial number 8901/00682 of 2009.

Variant 19, proposed on Table 2, followed the construction of a series composed of a cylinder, vibratory sticks, and a protective cover (Figure 5a), which comprised the harvester part (Figure 5b) responsible for detaching coffee fruits. The design team idealized the protective cover that wrapped the harvester cylinder, with the dual function of not

allowing the dispersal of fruits to areas beyond the projection of the trees, and thereby guaranteeing the safety of the harvester operation. Another variant that achieved a higher score was the proposal that included a plane rectangular sheet and parallel sticks perpendicular to this sheet (Figure 5c), which was a part of the complete harvester (Figure 5d).

With the detailed design in hand, it was possible to testify that the project methodology, when applied, enabled the development of two trailed coffee fruit harvesters, namely one with a commercial system consisting of a cylinder with radial sticks, and another composed of perpendicular sticks on a rectangular fixation sheet. In accord with the fabrication, the chassis had a maximum weight capacity of approximately 275 kg. This was the biggest problem in the development of the vibration and detachment mechanisms from variant 19, in which it was observed that the commercial cylinder with radial

sticks had an approximate weight of 800 kg (Figure 5a). By taking into consideration the maximum capacity of the chassis and the project focus on

presenting innovative characteristics, the team understood that the main challenge was posed by the virtual construction and detailing of variant 20.

Figure 5. Scheme of (a) harvester cylinder surrounded by the protective cover, (b) complete harvester (Variant 19), (c) harvesting mechanism, and (d) complete harvester (Variant 20).

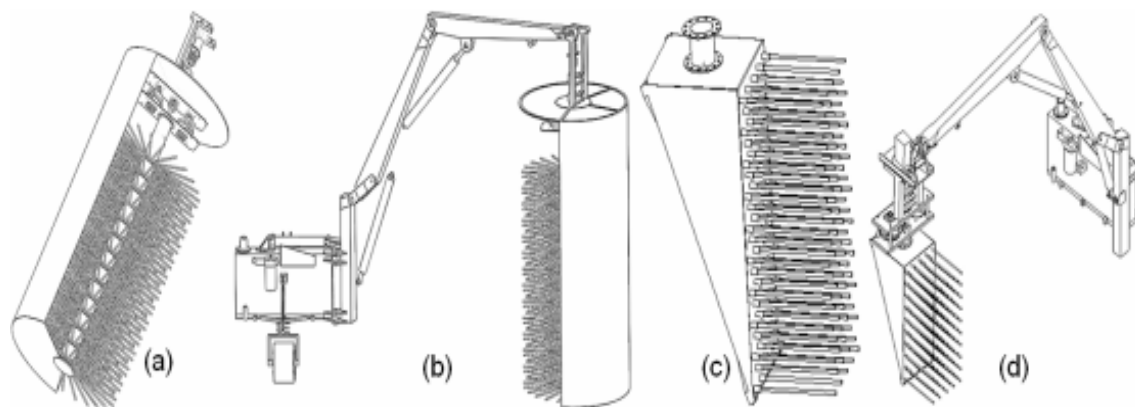

The virtual detachment mechanism was composed of a rectangular plane and perforated metal sheet, made with metal steel 1020, with a height of 0.5 m and a thickness of 0.05 m (Figure 6a). It also had eight nipple lines in steel 1020, with a length of 0.05 m, a diameter of 0.021 m, and a 0.042 m wall with brass hex nuts and nylon clamping (Figure 6b). A lateral reinforcement was

fabricated in steel 1020 with a thickness of 0.05 m (Figure 6c). The posterior truss system guaranteed stability with circular tubes in steel 1020, with an external diameter of 0.38 m and a wall with 0.03 m thickness (Figure 6d). The plan involved 86 rods (Figure 6e) with dimensions including a diameter of 0.013 m and a length of 0.63 m, with 43 fiber mat wires of TEX4400® with an approximate width of 0.015 m.

Figure 6. Scheme of (a) plane perforated metal sheet, with welded nipples, of (b) lateral reinforcement, (c) reinforced truss, (d) bronze nuts, and (e) fiberglass rod.

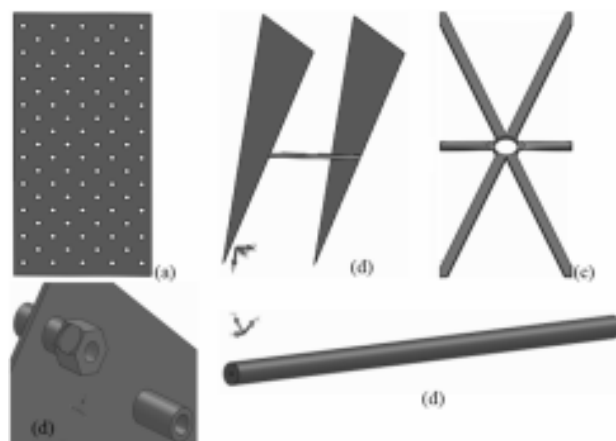

The virtual archetype composed by the articulated chassis and the detachment system achieved a total weight of 232 kg by taking into consideration weight properties and harvester constituent parts dimensions (Table 4). After the construction of the virtual archetype in CAD platform, the respective material dimensional characteristics, chassis parts positioning (hydraulic control and articulated arms), and the detachment system constituted by

the vibration and detachment mechanisms, it was possible to obtain the minimum and maximum angles of the articulated arm structures. This was achieved by employing positioning resources inside the mounting, among the articulations formed by the extensor articulated arms and elevation articulated arms (Figure 7a), by the gyre and elevation arms (Figure 7b), and by the gyre arms and the reservoir (Figure 7c), representing values on Table 5 and patent requirement BR102013031650.

Table 4. Properties of structural steel and glass fiberglass rods.

Material	Density(kg m ⁻³)	Young's modulus (MPa)	Poisson's ratio
Structural steel	7850	200000	0.3
Fiberglass	2000	42000	0.22

Figure 7. Maximum and minimum arm articulation angles of (a) extension and elevation, (b) gyre and elevation, and between the (c) gyre arm and the reservoir.

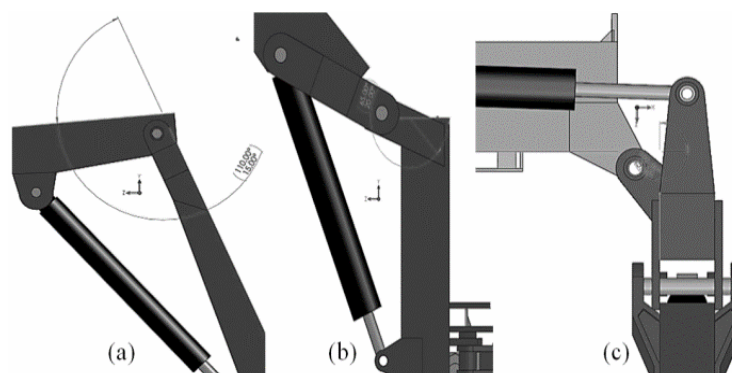

Table 5. Angular limits of the components of vertical and horizontal movements of the harvester.

Articulation	Angles (degrees)	
	Superior Limit	Inferior Limit
Extension and uprising	110	20
Gyre and uprising	65	20
Gyre arm and reservoir	100	45

After the fixation of maximum and minimum angles among the components presented in Table 5 and the limitations of movement among harvester components was concluded, it was possible to determine the maximum horizontal distance (Figure

8a) and the minimum horizontal distance (Figure 8b), as well as the maximum vertical distance (Figure 8c) from the detachment mechanism reach, in relation to the first coupling point of the tractor/ implement.

Figure 8. Horizontal (a) maximum and (b) minimum distances. (c) Maximum vertical reach of the detachment mechanism.

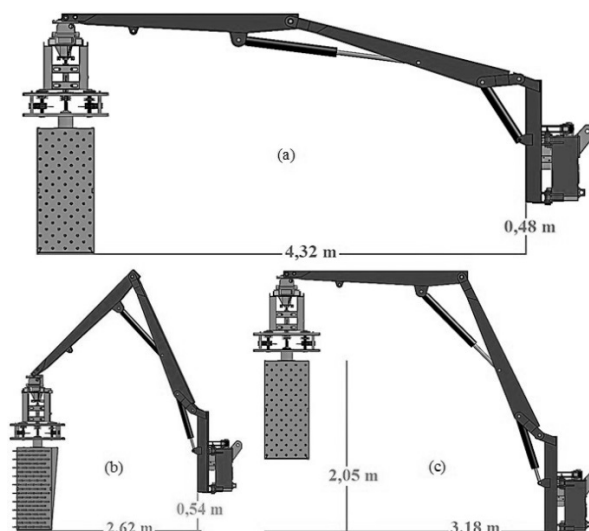

Given these dimensions in hand, it was possible to determine the scope and the maximum attempted height of the detachment mechanism as 4.32 m and 2.05 m at the planting line area, respectively in relation to the inferior basis of the gyre arm of the chassis. Figure 8 shows the innovative detachment mechanism, which was a result of applying and adjusting the project methodology in the course of the work on the tree canopy.

Conclusion

The composition of the design team composition united individuals and professionals with considerable expertise who directly dealt with mountain coffee harvesting problems as a part of their daily work. This facilitated the problem choice, and the construction and selection of the variants.

Given the development and the accomplishment of the chosen project methodology and the working environment conditions on terraced coffee plantations, it was possible to develop three possible archetypes of a coffee fruits harvester machine. Each arc was characterized by its singularity, related

to the structure and operation of the detachment mechanism.

The use of Computer Aided Design (CAD) permitted the evaluation of the weight properties of the detachment mechanism by the design team. It also facilitated virtual construction of the archetype and lastly, the selection of a unique virtual prototype.

Acknowledgments

I express my sincere gratitude to the Brazilian Government, and specifically to the National Council for Scientific and Technological Development (CNPq) for the material and financial support received. I also thank the Department of Agricultural Engineering and the Graduate Program of Agricultural Engineering of the Federal University of Viçosa (UFV) for the infrastructure and human resources employed during the projection of the archetype. Additionally, I would like to thank the UFV professors for their advice, EPAMIG and the City of Araçuaia for supporting the execution and field experiments, and the Federal Institute of Espírito Santo (Ifes) for supporting the project and providing the translation of this article.

References

- ALMEIDA, L. F. M.; CONFORTO, E. C.; SILVA, S. L.; AMARAL, D. C. Fatores críticos da agilidade no gerenciamento de projetos de desenvolvimento de novos produtos. *Produto & Produção*, Rio Grande do Sul, v. 13, n. 1, p. 93-113, 2012.
- ALBIERO, D.; MACIEL, A. J. da S.; MELO, R. P.; MELLO, C. A.; MONTEIRO, L. A. de. Metodologias de projeto para máquinas agroecológicas: relatos de experiências. *Cadernos de Agroecologia. Revista Brasileira de Agroecologia*, Cruz Alta, v. 6, n. 2, p. 1-5, 2011.
- ALBIERO, D.; MACIEL, A. J. da S.; LOPES, A. C.; MELLO, C. A.; GAMERO, C. A. Proposta de uma máquina para colheita mecanizada de babaçu (*Orbignya phalerata* Mart.) para a agricultura familiar. *Revista Acta Amazônica*, Manaus, v. 37, n. 3, p.337-346, 2007.
- ALBIERO, D.; MACIEL, A. J. da S.; MION, R. L.; VILIOTTI, C. A.; GAMERO, C. A. Proposta conceitual de colhedoras autopropelidas de açaí (*Euterpe oleracea* Mart.) para a Região Amazônica (*Euterpe oleracea* Mart.) para a Região Amazônica. *Revista Ciência Agrônômica*, Fortaleza, v. 43, n. 2, p. 382-389, 2012.
- ALBIERO, D. Desenvolvimento e avaliação de máquinas multifuncional conservacionista para a agricultura familiar. *Varia Scientia – Agrárias*, v. 2, p. 177-179, 2012.
- AHRENS, D. C.; SKORA NETO, F.; RIBEIRO, M. de F. S.; COSTA, A.; PEIXOTO, R. T. G.; MILLÉO, R. D. S.; BENASSI, D. A.; CAMPOS, A. C.; GOMES, E. P.; OLIVEIRA, C. F. de. Reflexões sobre a pesquisa participativa. *Revista Brasileira de Agroecologia*, Cruz Alta, v. 2, n. 1, p. 89-92, 2007.
- CARVALHO JÚNIOR, C. de; BOREM, F. M.; PEREIRA, R. G. F. A.; SILVA, F. M. da. Influência de diferentes sistemas de colheita na qualidade do café (*Coffea arabica* L.). *Ciência Agrotecnica*, Lavras, v. 27, n. 5, p. 1089-1096, 2003.
- CIRILLO JÚNIOR, E. Avaliação de tempo efetivo da derriça mecanizada e manual do café, na região de garça. *Revista Científica Eletrônica de Agronomia*, Garça, Ano VI, n. 11, p. 1-6, 2007.
- GRZEBIELUCKAS, C.; BUSON, M. A.; QUEIROZ, S. G.; ENSSLIN, S.; BALBIM, A. J. Instrumento para identificação das necessidades do consumidor no processo de desenvolvimento do design: um estudo ilustrado com o projeto de um automóvel. *Revista Gestão da Produção*, São Carlos, v. 18, n. 2, p. 337-350, 2011.
- INSTITUTO ANTONIO ERNESTO DE SALVO – IANES. Caracterização da cafeicultura de montanha de Minas Gerais. Coordenadores, Pierre Santos Vilela, José Luis dos Santos Rufino. Belo Horizonte: INAES, 2010. 300 p.
- MAGALHÃES, A. C.; COUTO, S. M.; QUEIROZ, D. M.; ANDRADE, E. T. Dimensões principais, massa e volume unitários, esfericidade e ângulos de repouso dos frutos de café. *Revista Brasileira de Produtos Agroindustriais*, Campina Grande, v. 2, n. 2, p. 39-56, 2000.
- MINISTÉRIO DA AGRICULTURA, PECUÁRIA E ABASTECIMENTO – MAPA. Informe estatístico do café 2013-2014, dezembro/2014. 2014. Brasília. Disponível em: <<http://www.agricultura.gov.br/vegetal/estatisticas>>. Acesso em: 04 ago. 2014.
- MOREIRA, R. M. G.; TEIXEIRA, M. M.; FERNANDES, H. C.; CECON, P. R.; MINETTE, L. J. Desenvolvimento de um revolvedor mecânico de café. *Semina: Ciências Agrárias*, v. 34, n. 6, p. 3655-3662, 2013.
- MOREIRA, R. M. G. *Desenvolvimento de máquina derriçadora de frutos de café em lavouras terraceadas*. 2015. Tese (Doutorado em Engenharia Agrícola) – Universidade Federal de Viçosa, Viçosa.
- PADILHA, A. C. M.; CARVALHO, F. F. de; MATTOS, P. de; GOLLO, S. S. A Gestão de design na concepção de novos produtos: uma ferramenta de integração do processo de gestão e inovação. *Revista de Administração da UFSM*, Santa Maria, v. 3, n. 3, p. 346-360, 2010.
- PAHL, G.; BEITZ, W.; FELDHUSEN, J.; GROTE, K. H. *Projeto na engenharia: fundamentos do desenvolvimento eficaz de produção – métodos e aplicações*. 6. ed. São Paulo: Editora Edgard Blucher, 2005. 412 p.
- ROMANO, L. N. *Desenvolvimento de máquinas agrícolas: planejamento, projeto e produção*. São Paulo: Blucher Acadêmico, 2013. 310 p.
- _____. *Modelo de referência para o processo de desenvolvimento de máquinas agrícolas*. 2003. Tese (Doutorado em Engenharia Mecânica) – Universidade Federal de Santa Catarina, Florianópolis.
- RUGANI, F. do L.; SILVEIRA, S. de F. R. Análise de risco para o café em Minas Gerais. *Revista de Economia e Agronegócio*, Viçosa, MG, v. 4, n. 3, p. 343-364, 2006.
- SEVERO, R. F.; ROMANO, L. N.; BENDER, A. R. K.; BOELTER, N. M. Relação entre os fatores de influência no projeto e a estrutura funcional de uma descascadora de mandioca. *Ciência Rural*, Santa Maria, v. 44, n. 9, p. 1568-1573, 2014.

SILVA, J. M. da; REIS, R. P. Custos de produção do café na região de Lavras/MG: estudo de casos. *Ciência Agrotécnica*, Lavras, v. 25, n. 6, p. 1287-1294, 2001.

STEFANELLO, G.; MACHADO, A. L. T.; REIS, A. V.; MACHADO, R. L. T.; MORAIS, C. S. D. Estrutura funcional de uma semeadora de tração humana. *Ciência Rural*, Santa Maria, v. 44, n. 9, p. 1583-1588, 2014.